

ISOTHERMAL

BINS



RIVAL

+ t u b o s +

▶ PRODUCT

Our new and innovative products are called **ISOTHERMAL BINS** which are the solutions for the aquaculture and fishing industry because they have a high quality.

Every industry looks for procedures to improve productivity, efficiency and cost reduction. Our isothermal bins are used for the transfer of fish and shrimp, providing a constant temperature for longer time while in use.

▶ BENEFITS

- **Prevents** the dehydration of the product, achieving a sale per kilo at its full weight.
- **Reduce** transportation costs, therefore it will not require units with thermo-insulated or refrigeration equipment.
- **Guarantees** a good quality of the product in long transfers, maintaining the refrigeration.
- **Forklifts** can be used, as well as manual loaders, because both have two ways of entry.

▶ CHARACTERISTICS / FEATURES

- Made of polyethylene having a food certification
- Double wall with polyurethane foam on base and cover
- Capacity of 1000 liters with a measurement scale inside
- Handles in 4 corners
- Stockable
- Recommended maximum staking of 2800 liters which means 4 units
- Drain system
- Bins can be customized



DIMENSIONAL DETAILS

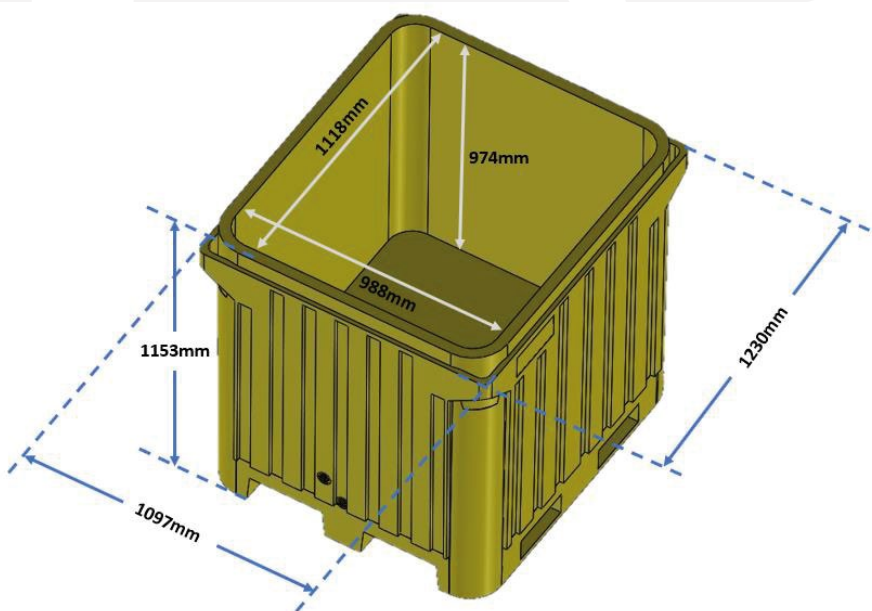



DIMENSIONAL DETAILS

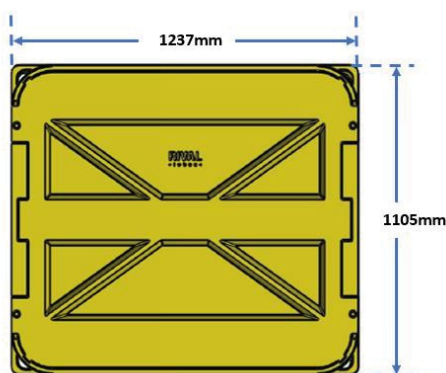
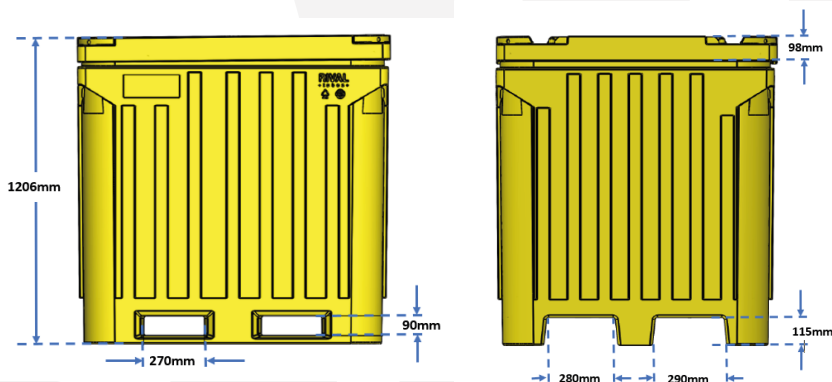

PRODUCT MANUFACTURES UNDER INTEGRAL MANAGEMENT SYSTEM



MADE IN ECUADOR BY

RIVAL

+ t u b o s +

www.plasticosrival.com

SALES:



ecommerce@plasticosrival.com



ventas@plasticosrival.com



+593 99 861 6897



Plásticos Rival



rivalplasticos



rival.tubos

www.tienda.plasticosrival.com

FIRST EDITION: July 2024